

# TVL2 Series



## Comfort-motion

### Feature

- Maximum load: 600N
- Maximum speed: 35mm/s
- Adjustable stroke (preset in factory)
- Adjustable mounting bracket
- Suitable for TV cabinet

Appendix			
Type	TVL2-series		
Max. load (N)	600N		
Max. speed (mm/sec)	35mm/sec		
Standard installation dimension	795mm	685mm	570mm
Standard stroke length	914mm	780mm	650mm
Mounting dimension (L)	650mm	545mm	430mm

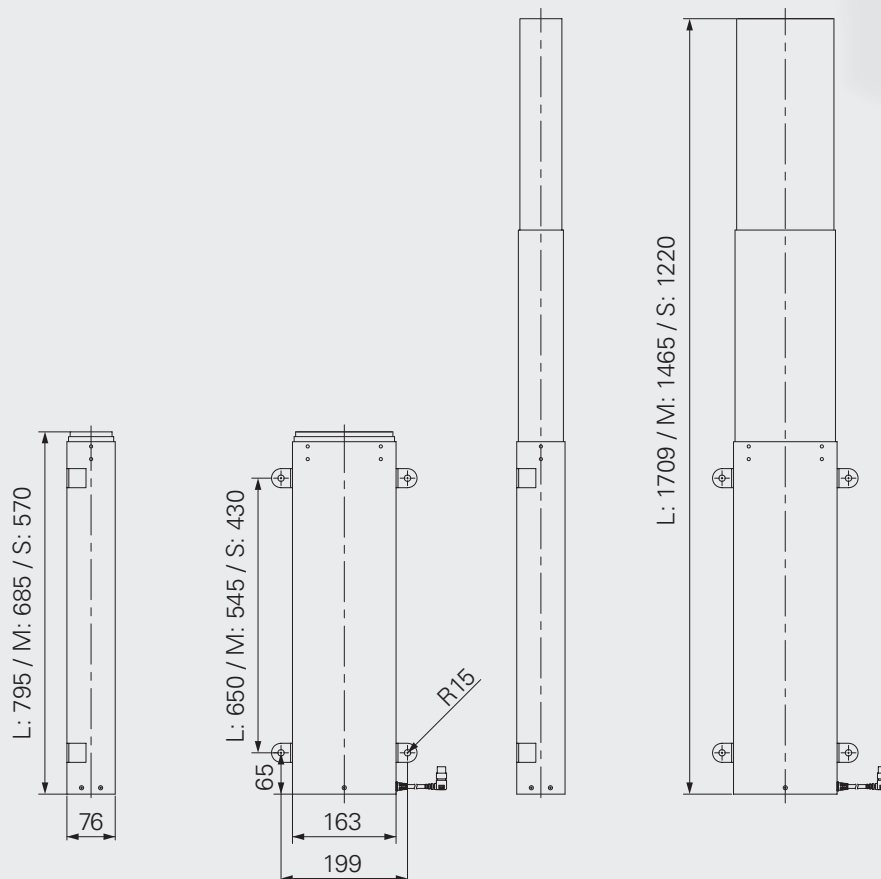

**Main Control Box (TC5-Series):**

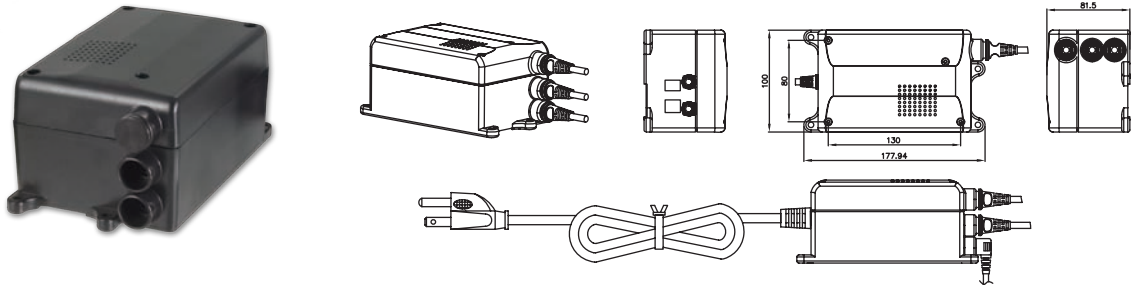

**Conceal Switch Box :**

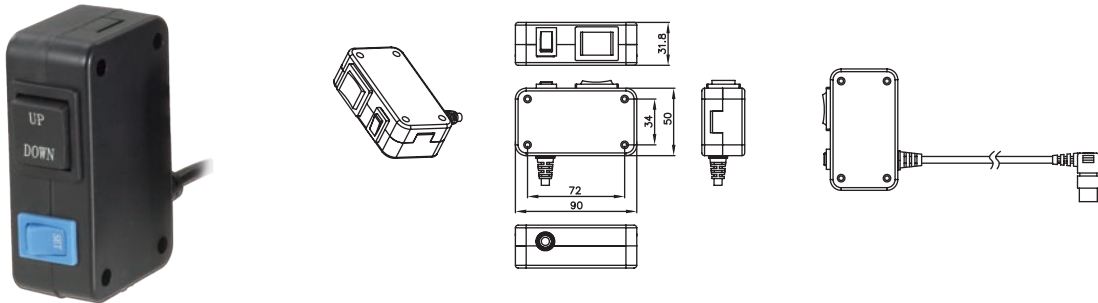

**IR receiver :**

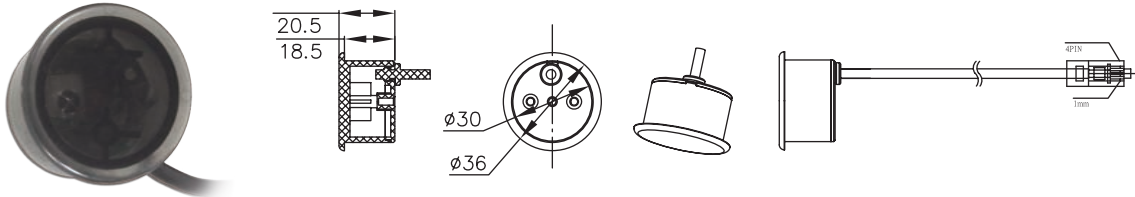

**Mounting Bracket (Option):**

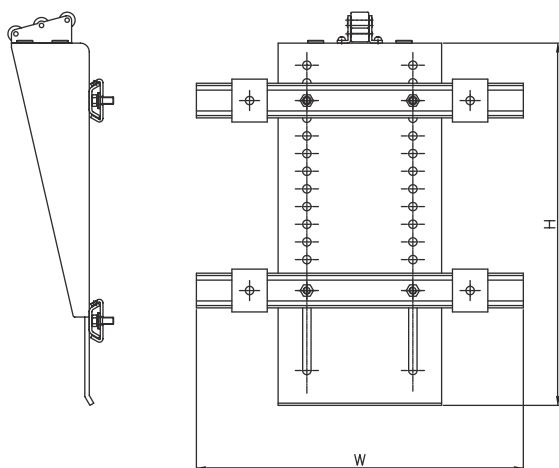

	W	H
L	760	510
M	660	450
S	550	410

**Remote Control :**

